

Figure 4.2.2-10: In 'Slab Results' section: Button "Displacements"① for 2nd time hides deformations. In 'FEM Results' section: Button "Details"② defines distribution per 0.1 m. Button sequence "Selection"③, "Bending", "V11", "Diagrams"④ displays the 3D view of the distribution of shear forces $[V_x]$.

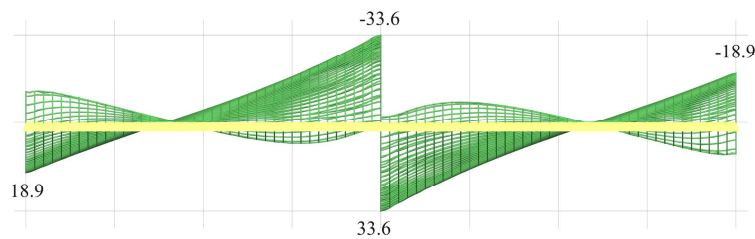

Figure 4.2.2-11: Button sequence "M", "View", "Options", "Front", "OK", "Quad" displays the front view of 3D distribution of shear forces $[V_x]$.

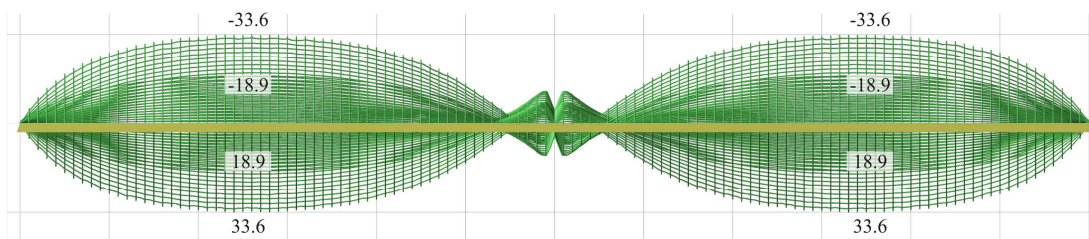

Figure 4.2.2-12: Button sequence "View", "Options", "Rear" displays the rear view of the 3D distribution of shear forces $[V_x]$.

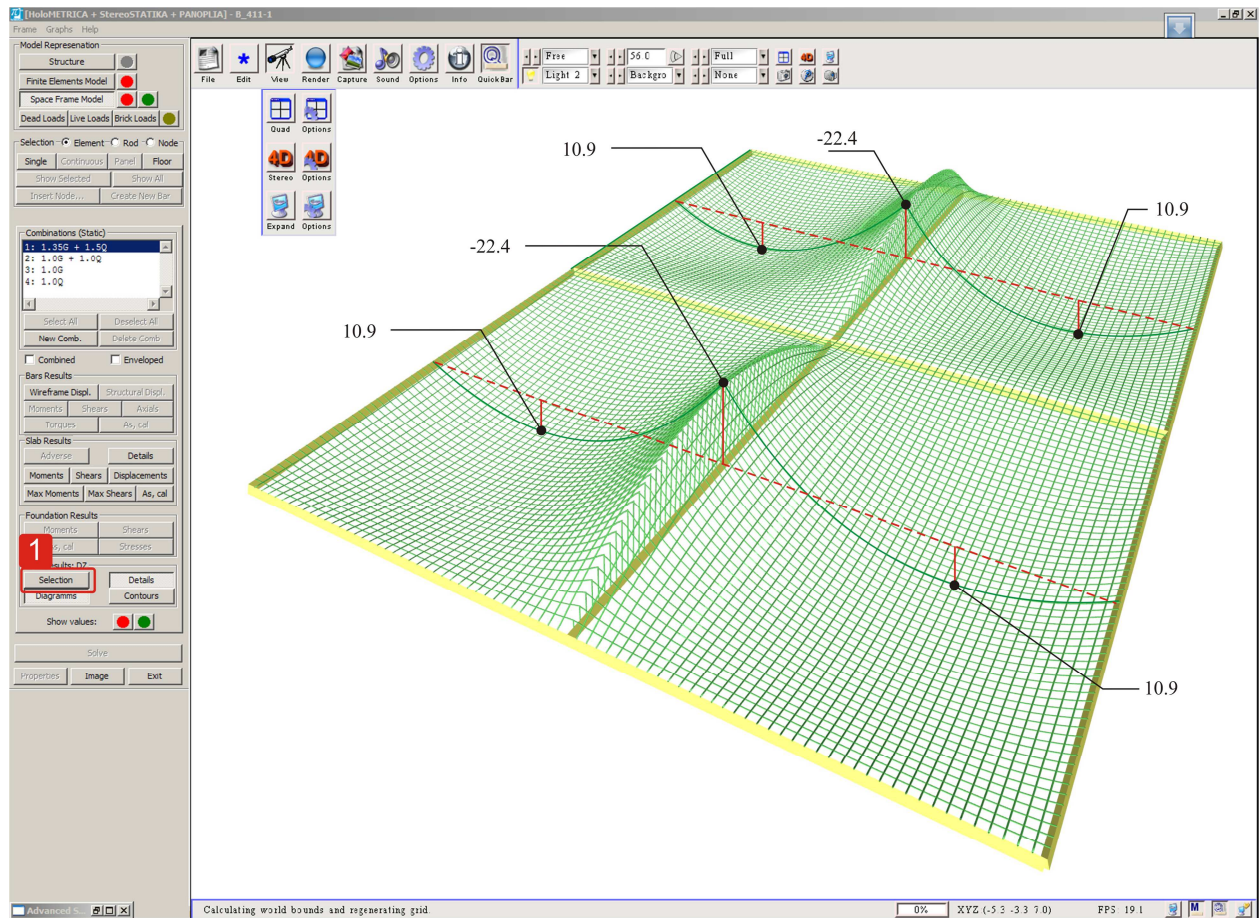



Figure 4.2.2-16: Button “Selection”, “Bending”, “M11” “Diagrams” displays the 3D view of distribution of bending moments $[M_x]$.

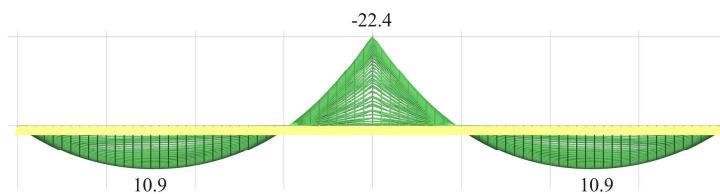



Figure 4.2.2-17: Button sequence “Selection”, “Bending”, “M11”, “Diagrams” displays the 3D view of distribution of bending moments $[M_x]$.

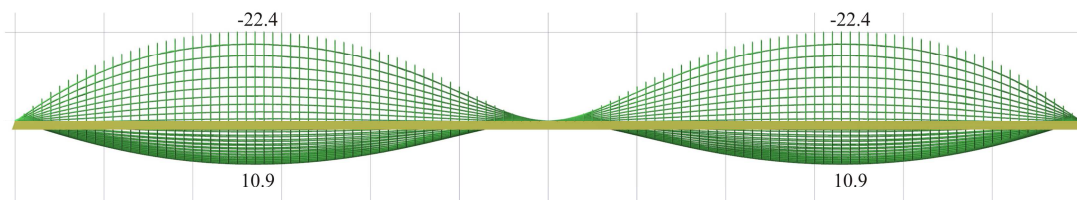

Figure 4.2.2-18: Button sequence “View”, “Options”, “Rear” displays the rear view of the 3D distribution of bending moments $[M_x]$.

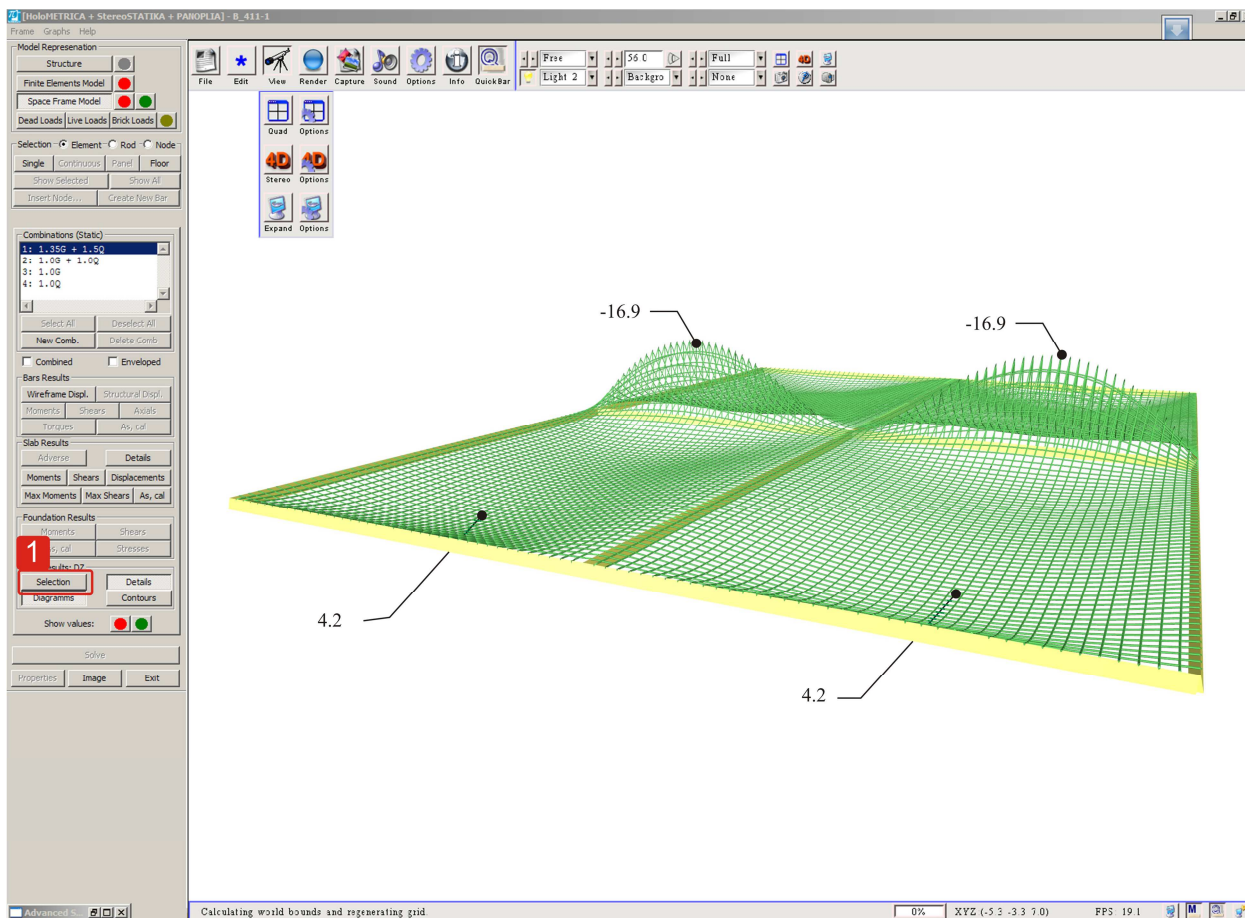

Figure 4.2.2-19: Button sequence “Selection”, “Bending”, “M22” “Diagrams” displays the 3D view of distribution of bending moments $[M_y]$.

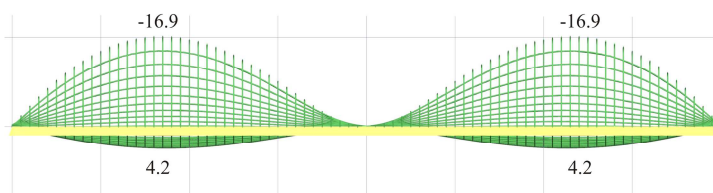

Figure 4.2.2-20: Button sequence “View”, “Options”, “Front”, “Quad” displays the front view of the 3D distribution of bending moments $[M_y]$.

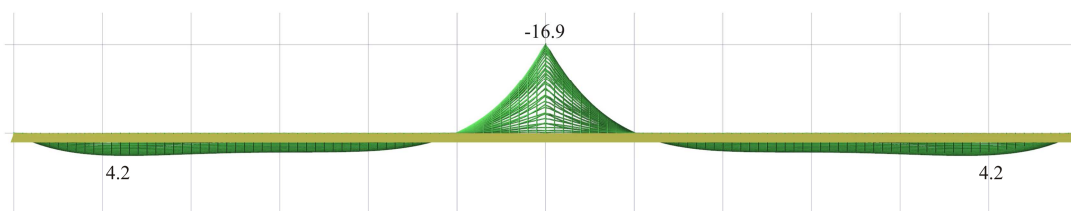

Figure 4.2.2-21: Button sequence “View”, “Options”, “Rear” displays the rear view of the 3D distribution of bending moments $[M_y]$.